



SA'S PREMIUM
CNC
MANUFACTURER

Uni-Grip Machining Centre

Vacuum Pods | Clamping | 1800 x
4500 mm | Automatic Tool Changer

Unicam's wood and composite board machining center. Designed for Solid wood, Panels and Jig work. This machine can cut on 5 faces of a board using an ATC with aggregate heads or a Bi-Rotary spindle. Different sizes & options available.

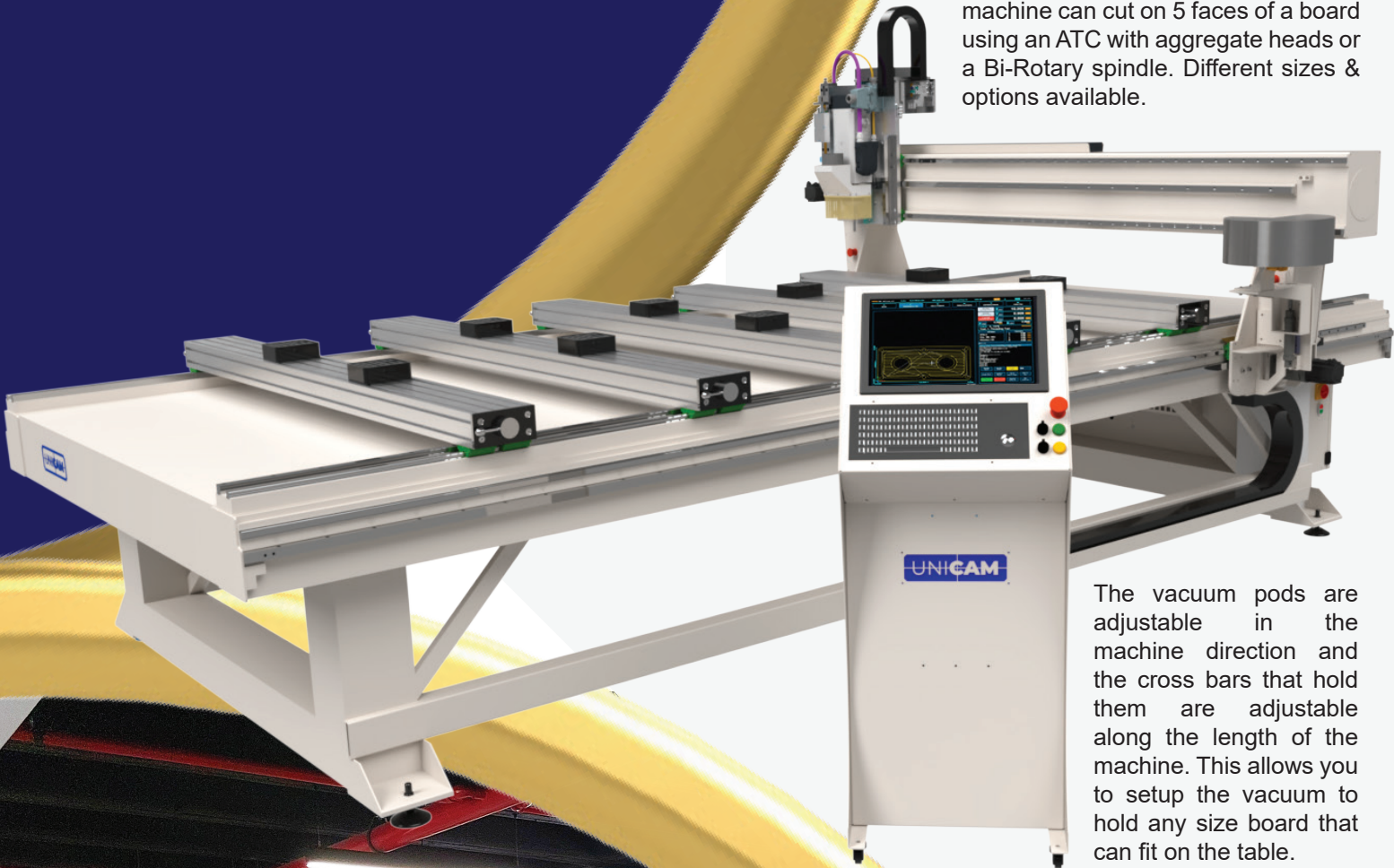

The vacuum pods are adjustable in the machine direction and the cross bars that hold them are adjustable along the length of the machine. This allows you to setup the vacuum to hold any size board that can fit on the table.

There are other attachments that can be mounted on the cross bars, such as clamps, vises and jigs.



Head Office (Cape Town): +27 (0)21 555 3247

Gauteng Office: +27 (0) 74 808 4036

Leaflet Uni-Grip 20240412

Uni-Grip

Machining Centre

Vacuum Pods | Clamping | 1800 x 4500 mm | Automatic Tool Changer

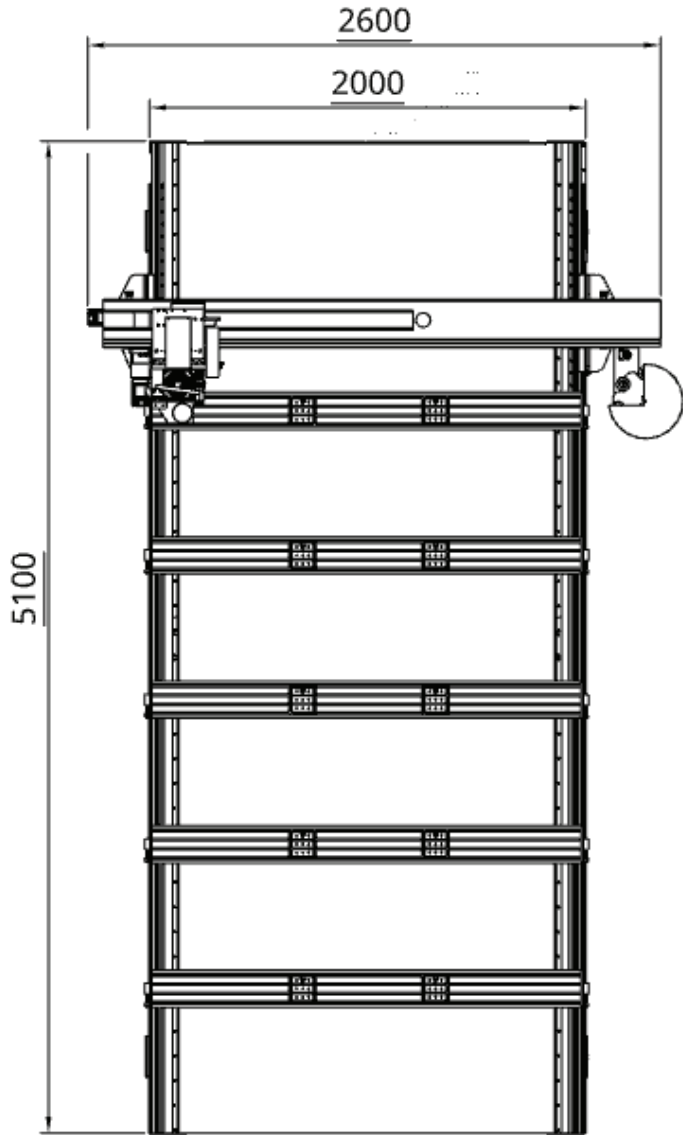

SA'S PREMIUM
CNC
MANUFACTURER

SPECIFICATIONS

Max Material Size:	1800 x 4500 mm
Securing System:	Vacuum Pods & Clamping System
Vacuum Generator:	Claw Type
Spindle Power:	9.5 KW
Spindle Max RPM:	24000
Spindle Type:	ATC
Spindle Cooling:	Air Cooled
Tool Station:	8 Tool Carousel
Tool Probe:	Yes
Max Feed Rate:	40 M/Min
Max Cutting Rate:	25 M/Min
Dust Foot:	Yes
Frame Material:	Epoxy Coated Mild Steel
Power:	380v 3PH 40 A
Compressed Air:	6-8 Bar

OPTIONS

Max Material Size:	1200 x 3000 1200 x 4000 1800 x 4500
Securing System:	Vacuum Pods Clamping System Vice
Vacuum Generator:	Claw Type / Side Channel Blower
Spindle Power:	7.5 KW 9.5 KW
Spindle Max RPM:	24000
Spindle Type:	ATC Birotary
Spindle Cooling:	Air Cooled
Tool Station:	8 Tool Carousel 12 Tool Carousel
Tool Probe:	Yes
Max Feed Rate:	40 M/Min
Max Cutting Rate:	25 M/Min
Dust collection:	Dust Foot Enclosed Gantry



email: sales@unicam.co.za

Website: www.unicamcnc.com

Head Office (Cape Town): +27 (0)21 555 3247

Gauteng Office: +27 (0) 74 808 4036



Jean-Marc Duquenoey
Managing Director



Alan Welsford
Founder / CEO



Glen St Joseph
Technical Director



Sadha Govender
Sales Engineer (Gauteng)

