

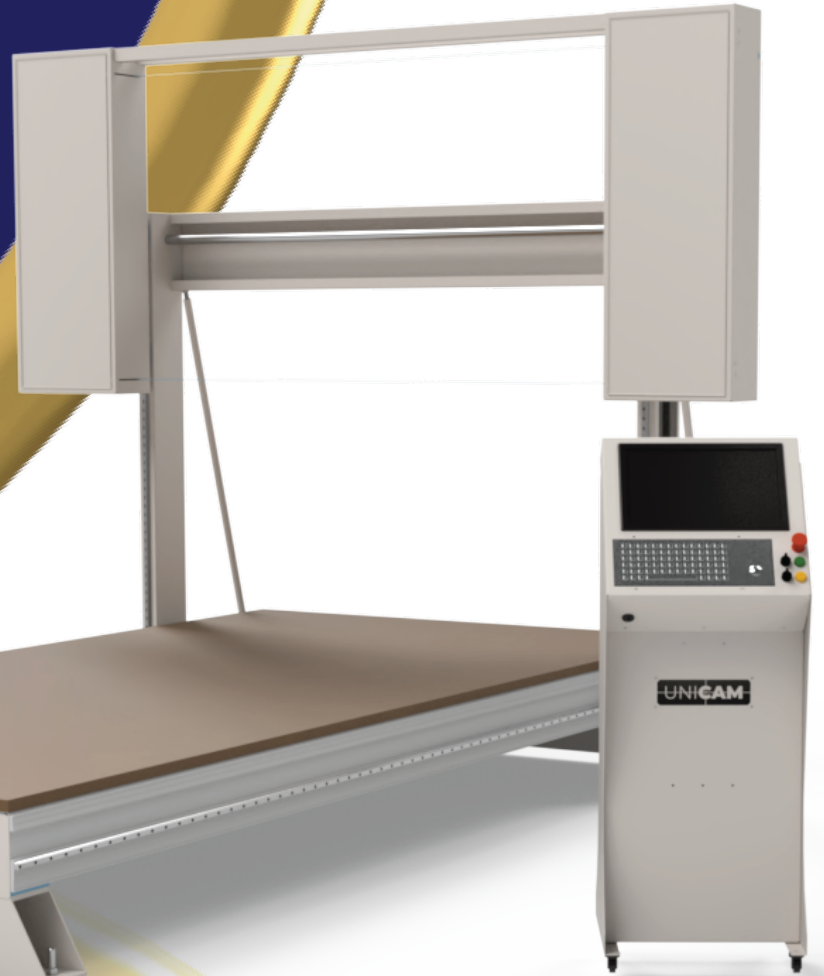

SA'S PREMIUM
CNC
MANUFACTURER

Fast Wire

Used for cutting Foam, Rock-wool or other low density materials. It cuts using a wire running at high speed that uses friction to cut the material.



The wire is horizontal and cuts right through the material from left to right. The wire can be moved in the Y and Z axis to create sheets or shapes out of a block of material. Commonly used for cutting isolation for pipes and foam for upholstery.

[See website for details.](#)



Head Office (Cape Town): +27 (0)21 555 3247
Gauteng Office: +27 (0) 74 808 4036

Fast Wire 20240908

Fast Wire

2000x3000x900

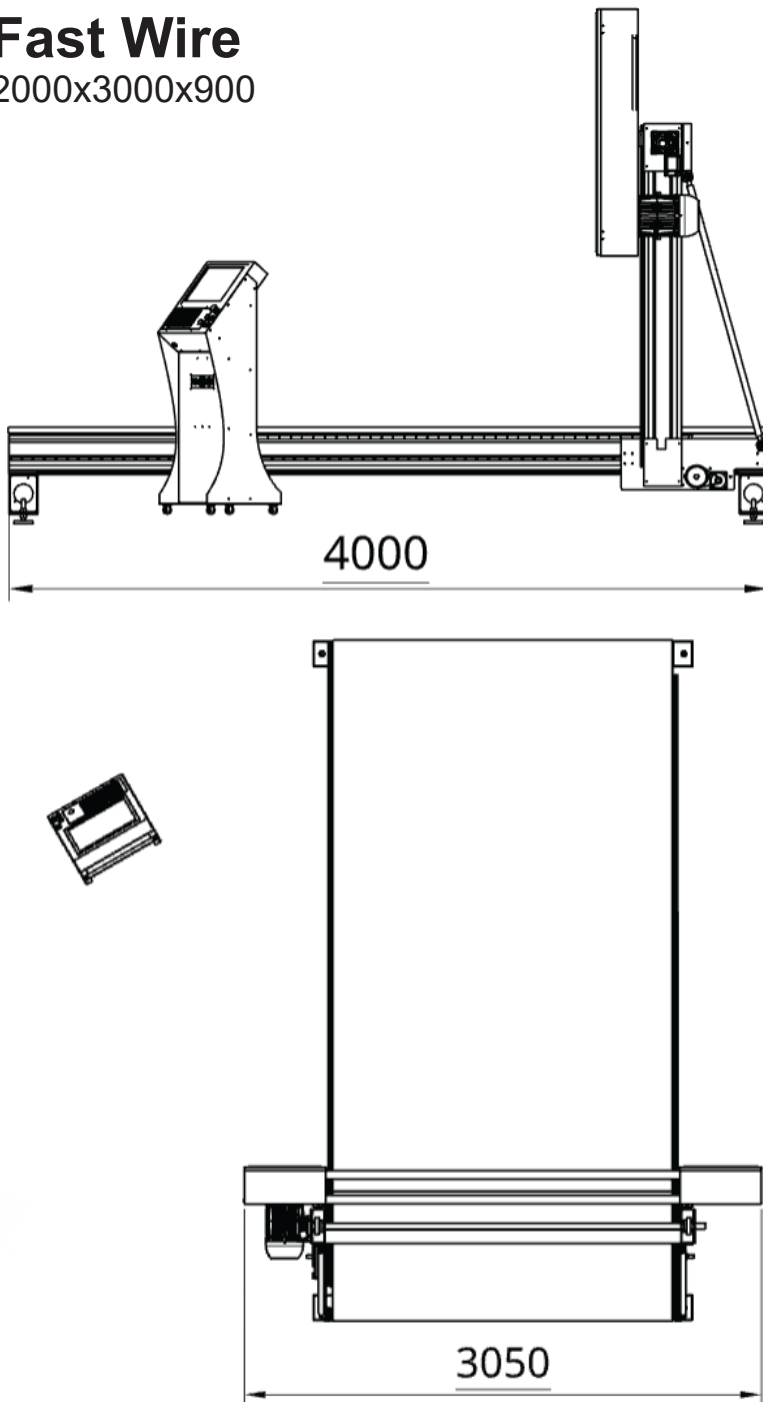

SA'S PREMIUM
CNC
MANUFACTURER

SPECIFICATIONS

Max Material Size	2400 x 1200 x 900 2400 x 1200 x 1200 3000 x 2000 x 900 3000 x 2000 x 1200 3000 x 2000 x 2000
Position Control:	Servo Drives 1Kw
Securing System:	Material weight or Vacuum
Spindle Power:	5 KW
Spindle Max RPM:	4000 RPM
Spindle Cooling:	Air Cooled
Max Feed Rate:	15 M/Min
Max Cutting Rate:	5 M/Min
Dust Control:	Dust Extractor
Frame Material:	Coated Mild Steel
Power:	380v 3PH 5A
Compressed Air:	6-8 Bar



email: sales@unicam.co.za

Website: www.unicam.co.za

Head Office (Cape Town): +27 (0)21 555 3247



Jean-Marc Duquenoy
Managing Director



Alan Welsford
Founder / CEO



Glen St Joseph
Technical Director



Vincent Taylor
Sales Manager

